

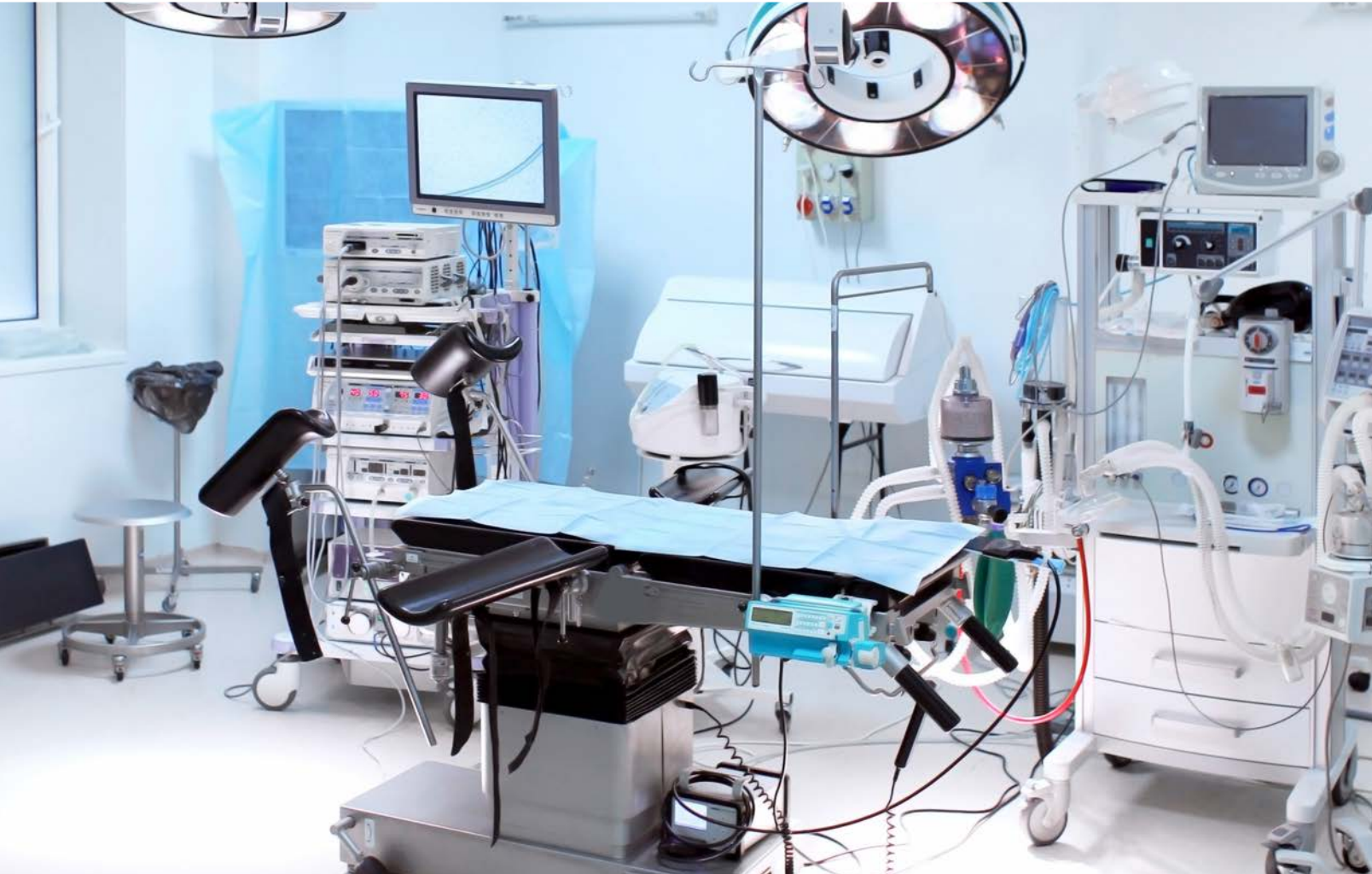

# The Need For EMI Filtering in Medical Devices



# TABLE OF CONTENTS

---

<b>Introduction</b>	<b>2</b>
<b>Requirements</b>	<b>2</b>
<b>What Can We Do?</b>	<b>3</b>
<b>Filter Parameters</b>	<b>3</b>
Stopband/Passband	3
No Load/Full Load	3
Rated Current/Current Overload/Leakage or Reactive Current	4
Rated Frequency	4
Rated Voltage/Voltage Drop/Overshoots	4
Dielectric Withstand	5
Insulation Resistance	5
Final Thoughts	5
<b>References</b>	<b>5</b>
<i>Please see last page for Schaffner USA Contact Information</i>	6

---

## INTRODUCTION

In today's society, medical devices can usually be found in the forefront of incorporating new technologies. This includes the ever-increasing use of sensitive analog electronics, wireless/RF, and microprocessors in all kinds of devices ranging from a relatively simple one like an electrical nerve stimulator to the more advanced device such as the magnetic resonance imaging (MRI) system. In the medical industry, there is also a tendency toward more automation to monitor patients and help perform diagnosis. At the same time, there is an increase of new communications technologies such as Bluetooth, Wi-Fi, and other various wireless computer links. All types of wireless technology face challenges coexisting in the same space. For example, devices operating under FCC Part 15 rules must accept any interference from primary users of the frequency band. (Note: FCC Part 15 is applicable to certain types of low-power, non-licensed radio transmitters and certain types of electronic equipment that emit RF energy unintentionally).

With all of these advances, there are some unforeseen problems such as the interactions between the products emitting the electromagnetic (EM) energy and other sensitive medical devices (intersystem interference). Even the medical devices

themselves can emit EM energy which can react themselves (intrasystem interference).

Electromagnetic compatibility, or EMC, means that a device is compatible with its electromagnetic (EM) environment including itself (i.e., no interference is caused) and it does not emit levels of EM energy that cause electromagnetic interference (EMI) in other devices in the vicinity. A medical device can be vulnerable to EMI if the levels of EM energy in its environment exceed the EM immunity of itself or any nearby device. The different forms of EM energy that can cause EMI are conducted, radiated, and electrostatic discharge (ESD). This is why the Food and Drug Administration (FDA) is concerned with the need to assure electromagnetic compatibility (EMC) between devices and the myriad of other devices both medical and non-medical. The manufacturer can design and test for emissions and immunity, but they do not have any control over the environment in which it will be used. The environment can change to one that is not anticipated by the manufacturer. This is why manufacturers must design their device with adequate protection against possible interfering emissions and immunity.

---

### Requirements

The consequence of electromagnetic interference (EMI) with medical devices may be only a transient "blip" on a monitor, or it could be as serious as preventing an alarm from sounding or inappropriate device movement leading to patient injury or death. While the numbers of reports with possible links to EMI have been steady, these numbers are generally not indicative of the actual occurrence of incidents. Indeed, in investigating possible EMI-related problems it is usually the case that the EM energy which caused the issue may have simply been shut off or removed from the area. Only through careful measurement and testing can the true nature of EMI immunity be determined. The Center for Devices and Radiological Health (CDRH) has regulatory authority over medical devices. Because of its concern for the public health and safety, the CDRH part of FDA has been the leader in the US of examining medical device EMI (electromagnetic interference). Extensive laboratory testing by CDRH, and others, has revealed that many devices can have immunity problems caused by EMI. The primary standard required by the CDRH/

FDA in the US is IEC 60601-1-2: International Electrotechnical Commission – Medical Electrical Equipment - Part 1-2: General Requirements for Safety - Collateral standard: Electromagnetic Compatibility - Requirements and Tests.

As was mentioned earlier, the concept of EMC can be divided into emissions and immunity threats. Emissions can be further divided into conducted emissions and radiated emissions. The primary immunity threats are radiated immunity, power disturbances and electrostatic discharge (ESD). Emissions need to be controlled so that the energy generated by the device in question does not cause a problem to any nearby equipment. Radiated immunity deals not only from its own emissions, but more to intentionally transmitted electromagnetic energy due to RF from commercial, broadcast, and military or aircraft communications. Power disturbances can be continuous or transitory in nature caused by nearby "noisy" equipment. Electrostatic discharge (ESD) is due to a gradual buildup of charges, but creates an issue when the charge buildup reaches an amplitude sufficient to create a discharge generating a conductive current surge and localized radiated transient field. Don't forget that

EMC includes self-compatibility meaning that your equipment should not generate a powerful enough field to interfere with its own operation.

## What Can We Do?

Unfortunately, EMC is typically the last step in a design. When all the other product features have been implemented and the functionality is established, any EMC problems are then solved. At this point, EMC becomes expensive, time-consuming and difficult to handle. Manufacturers should therefore always start thinking about EMC in the early stages of product design. This thought process pertains to the EMI power input filter as well. Designers often forget that an EMI filter can assist not only with conducted emissions, but also in meeting immunity and fast transients requirements along with radiated emissions too. A power line or mains EMI filter is placed at the power entry point of the equipment it is being installed in to prevent EM noise from exiting or entering the equipment. Even for military/aerospace equipment, they must be protected from failure due to EMI noise and security requirements may call for filters to protect classified data.

The design parameters for selecting an appropriate EMI filter include the attenuation or insertion loss, rated current, rated voltage, and regulatory approval requirements specified by the user. However, there are many other parameters that should be or must be considered to get the most efficiency, reliability, and proper operation from the filter. The intent of the remainder of this article is to present what some of the more important filter parameters are, and should be considered.

## Filter Parameters

### STOPBAND/PASSBAND

Filters are typically characterized by their insertion loss (IL), which is expressed in dB. The insertion loss is a measure of the load reduction at the given frequency due to the insertion of the filter. It is very important to note that the insertion loss of a filter is dependent on the source and load impedances, and thus cannot be stated independently of the terminal load/source impedances. Despite this fact, filter manufacturers often list an insertion loss value on a filter's data sheet without specifying these impedance values. A common mistake is to use a filter solely based upon the standard 50 Ohm input/50 Ohm output insertion loss that is typically published by the filter manufacturer's catalog data per MIL-STD-220. When this occurs, it can be misleading, because for that particular filter to work properly with your device, the input impedance seen looking into the power cord of your device must be 50  $\Omega$ . Since this is a rather unrealistic design constraint to place on a product, it is unlikely that the use of such a filter on your product will result in the filtering results specified by the manufacturer's insertion loss data. This is why the selected filter

must still be tested in the actual system to verify results.

Filters should not be expected to provide voltage regulation, clamping or smoothing. The value of inductive reactance should be kept small to prevent excessive distortion of the power frequency. The maximum value of line-to-line capacitance (differential mode) reactance should be no less than 100 times the filtered device's input impedance. These two simple rules will help avoid power frequency issues such as voltage drop or waveform distortion. Test the filter for both common mode and differential mode attenuation. Adequate differential mode and common mode filtering must fit the potential problem (see *Figure 1*). Remember that any filter schematic is only an approximation of the filter circuit especially at higher frequencies. In real life, the filter components exhibit tolerance, saturation, and parasitics as well as coupling.

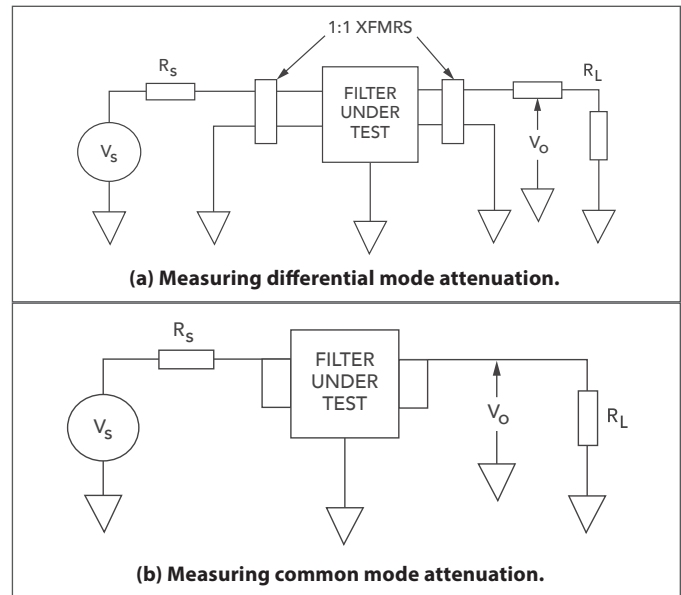

Figure 1. A Typical Test Setup for Measuring Filter Attenuation.

To design a good filter, the passband must be defined just as the potential interference frequencies. The level of anticipated interference should be approximated. Comparing this to the required EMC standard will yield the degree of necessary insertion loss or attenuation.

Unless the design engineer has experience in filter designing, it is recommended that such assistance be called upon from a potential filter manufacturer like Schaffner EMC, Inc. EMI test laboratories can also provide many filter choices.

### NO LOAD/FULL LOAD

The filter's insertion loss or attenuation characteristics should be verified not just at the "no load", but for the "full load" current levels as well (see *Figure 2*). Since inductors are one of the key components in the filter, it is important to note that variables such as the type of core material and saturation current level through the inductor can affect the value of the choke. Using the smallest L value possible and keeping the inductor ESR small will help. For more information, see the

Rated Current section below.

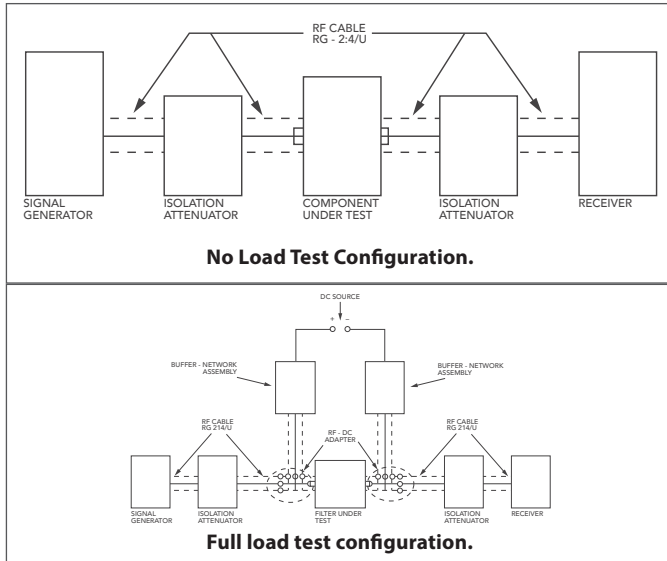

Figure 2. Typical Test Setup for no load/full load measurement.

## RATED CURRENT/CURRENT OVERLOAD/LEAKAGE OR REACTIVE CURRENT

**Rated Current** – The rated current should be equal to the maximum input current to be drawn from the device being filtered. Chokes consist of an electrical conductor wound around a material with magnetic characteristics, the core. The choke always makes use of its magnetic characteristics to suppress RF noise. The core material determines the performance of a choke. It enhances the magnetic effects in the choke, improves the suppression characteristics and leads to more compact components. Core materials are also dependent on outside factors such as temperature or current. When used outside of its specified current range, a choke can saturate, leaving it unable to supply its original impedance (see Figure 3).

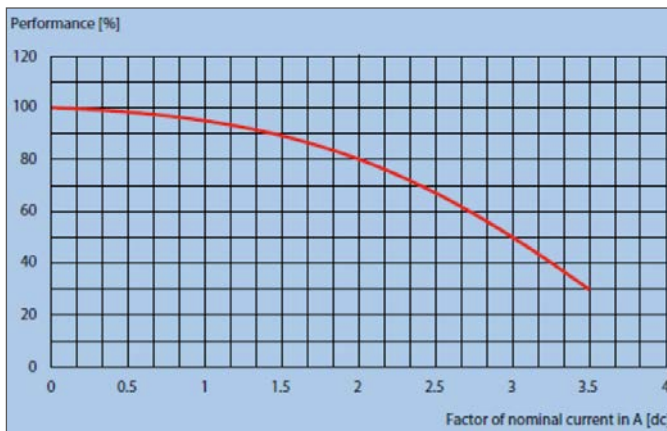

Figure 3. Saturation of a Typical Choke Due to Current.

**Current Overload** – Current overload characteristic of a filter demonstrates the filter’s ability to withstand the heat dissipated by the filter’s components when subjected to a higher than rated current of the filter. Typically, it is performed per paragraph 4.6.10 of MIL-F-15733 at 140% of the rated current under rated frequency for 15 minutes. After the required time

period, insulation resistance and voltage drop (see Figures 5 and 7) must be repeated.

When the power is turned on, current begins to flow, and the initial current flow reaches a peak current value that is larger than the steady-state current value. Following this, the current value gradually decreases until it stabilizes at the steady-state current. The part during which a large current flows before reaching the steady-state current is the inrush current. If the size of the inrush current exceeds that allowed by the part in use, depending on the magnitude of the inrush current (difference between the peak current value and the steady-state current value) and length of its duration (the length of time until the peak current value converges with the steady-state current value, hereafter called the pulse width), the part used in the circuit may overheat, potentially causing the electrical device to malfunction or break down.

**Leakage Current** – During normal operation of electrical equipment, some current flows to earth. Such currents, called leakage currents, pose a potential safety risk to the user and are therefore limited by most current product safety standards. Examples for these standards are EN 60950-1 for information technology equipment, IEC60601 for medical equipment or UL 1283 for passive EMI filters. The standards include limits for the maximum allowed leakage current. The typical leakage current values for a Class I device (protective earth) are 300  $\mu$ A in a patient-care area and 500  $\mu$ A outside that area. For a Class II device (double insulated), the values are 150  $\mu$ A in a patient-care area and 250  $\mu$ A outside that area. For passive EMI filters it is common to calculate the leakage currents based on the capacitor values against earth and other parasitic components. This leakage current is limited by the international safety agencies to prevent a danger to personal safety.

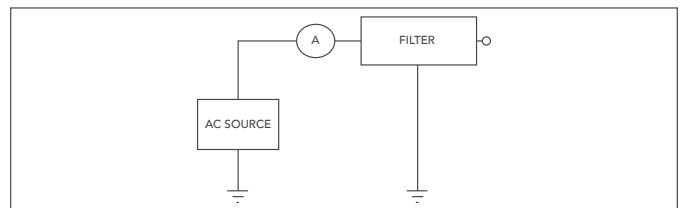

Figure 4. Leakage Current Test Circuit.

## RATED FREQUENCY

The frequency of the AC mains supply is either 50 or 60 Hz. The operating frequency of the filter is determined by the behavior of the capacitors. Depending on the voltage/frequency characteristic of the capacitor, it might be possible to operate a filter at a higher frequency but with a reduced input voltage.

## RATED VOLTAGE/VOLTAGE DROP/OVERSHOOTS

**Rated Voltage** – The rating voltage should be equal to or greater than the maximum input voltage to be supplied to the device being filtered. The rated voltage of the filter defines the maximum continuous operating voltage, i.e., the maximum voltage at which the filter should be used continuously. Short overvoltages are permitted in accordance with

IEC 60939, but to avoid damage to the filter capacitors, the continuous voltage should not exceed the rated voltage for an extended period of time.

**Voltage Drop** – The impedance of the filter is measured at the relevant power network frequency, i.e., 50 Hz for European applications and 60 Hz for North American applications. This is performed at a defined temperature, such as 25 °C. Current flowing through this impedance, of course, will cause a voltage drop across the filter resulting in a change in the voltage seen at the load end of the filter.

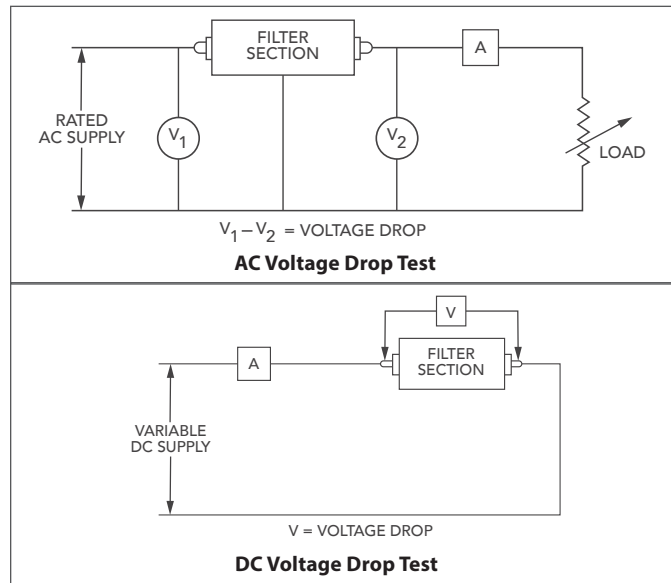

Figure 5. Typical Voltage Drop Test Configuration.

**Overshoots** – Voltage overshoots and voltage peaks can come with high dv/dt values but are also a problem on their own. The inductance of the filter acts like a choke according to the energy storage principle. If chokes are subject to voltage pulses, voltage peaks occur every time switching on or off takes place. The higher the energy content (inductance) of the choke, the higher these voltage peaks become. These amplitudes can, in turn, reach values that cause a stress situation in the winding insulation.

## DIELECTRIC WITHSTAND

Dielectric testing, sometimes referred to as Hi-Pot testing, demonstrates the ability of the filter capacitors to ensure higher than rated voltage. In filters, components are used that are connected between the phases of the supply network or between one phase and earth. It is therefore important to determine how well filters resist high voltages.

A dielectric withstand test is performed for this reason by applying a voltage between enclosure and phase or between two connectors for a defined time. The current flowing between the same points is measured. Current flow means that the insulation is broken; the equipment fails the test.

During approval procedures, the test is usually performed over a longer period (typically one minute) with a defined voltage.

Many safety standards require the testing to be performed on 100 % of all units, but to save time, a test with higher voltage but reduced time is accepted. It should be noted that repeated high-voltage testing can lead to a damage of the insulation. Please note that this test is a high-stress test for the capacitors inside the filter. Each additional test stresses the capacitors again and leads to a reduction of lifetime. Schaffner recommends keeping the number of tests to a minimum and never test the filters at higher than the indicated voltages.

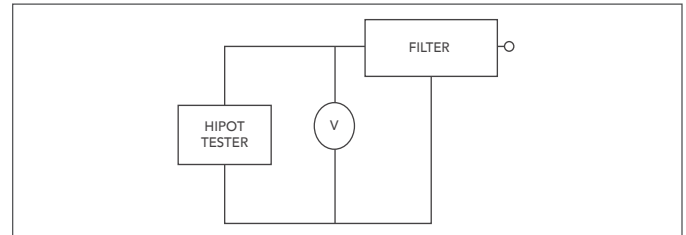

Figure 6. Typical Test Setup for Dielectric Withstand or Hi-Pot.

## INSULATION RESISTANCE

Insulation resistance indicates quality of the filter capacitor construction and filter insulation system. Low insulation resistance may indicate a condition which may lead to possible deterioration over time. Sometimes this can be calculated from measurements of the DC leakage current at the specified voltage.

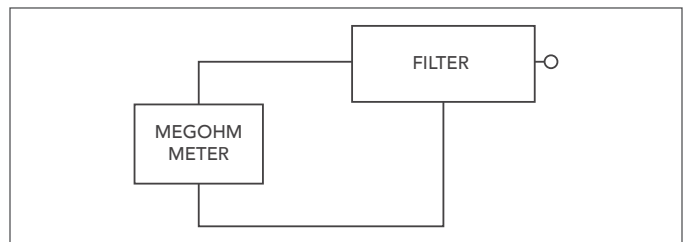

Figure 7. Setup for Insulation Resistance Test.

## FINAL THOUGHTS

Schaffner not only can provide off the shelf EMC filter solutions but also support manufacturers with their EMC layout from the early stages of new product ideas or designs. Schaffner can also offer custom made solutions to help manufacturers meet any unique electrical, mechanical or EMC challenge. Contact your nearest Schaffner representative for assistance.

## References

1. **Medical Devices and EMI: The FDA Perspective**, Don Witters, Center for Devices and Radiological Health, Food and Drug Administration, Rockville, MD 20850.
2. **Electromagnetic Compatibility for Medical Devices – Issues and Solutions Conference Report**, Association for the Advancement of Medical Instrumentation, 1996.
3. **Electromagnetic Compatibility in Medical Equipment – A Guide for Designers and Installers**, William D. Kimmel and Daryl D. Gerke, IEEE Press and Interpharm Press, Inc., 1995

**SCHAFFNER  
EMC INC.**

52 Mayfield Avenue  
Edison, New Jersey 08837  
+1 800 367 5566  
+1 732 225 4789  
usasales@schaffner.com  
www.schaffnerusa.com

**Product Types**

Ecosine active  
EMC/EMI  
Power quality

**Responsible For**

USA  
Brazil  
Canada  
Mexico

